

Development of lotus-type porous material for heat pipe application using centrifugal slip casting process

by Bambang Ariantara -

Submission date: 23-May-2023 08:44AM (UTC+0700)

Submission ID: 2099689656

File name: Development_of_lotus-type_porous_material_for_heat_pipe.pdf (767.93K)

Word count: 3023

Character count: 15049

PAPER · OPEN ACCESS

Development of lotus-type porous material for heat pipe application using centrifugal slip casting process

To cite this article: S Supriadi *et al* 2018 *IOP Conf. Ser.: Mater. Sci. Eng.* **432** 012001

View the [article online](#) for updates and enhancements.

You may also like

- [LTP – LISA technology package: Development challenges of a spaceborne fundamental physics experiment](#)
R Gerndt and (for the entire LTP Team)
- [A novel strategy to obtain superfine modified SiC powder with binary modifier: disperse black/sodium alginate and its mechanism study](#)
Shichao Sun, Wenxiao Zhang and Jiayang Liu
- [Battery thermal management system using loop heat pipe with LTP copper capillary wick](#)
Bambang Ariantara, Nandy Putra and Sugeng Supriadi



The Electrochemical Society
Advancing solid state & electrochemical science & technology

243rd Meeting with SOFC-XVIII
Boston, MA • May 28 – June 2, 2023
Accelerate scientific discovery!

Learn More & Register



Development of lotus-type porous material for heat pipe application using centrifugal slip casting process

S Supriadi^{1*}, M Rasis¹, T Heriyanto¹, B Ariantara¹, and N S D Putra¹

¹ Departement of Mechanical Engineering, Faculty of Engineering, University of Indonesia, UI Depok, Depok 16424 Indonesia

sugeng@eng.ui.ac.id

Abstract. Heat pipe is a heat conductor which has a large conduction capacity using a special fluid-filled pipe as a conductor of heat from the hot end (evaporator) to the cold end (condenser) used for thermal management. In the heat pipe, there is a sintered wick which transfers refrigerant fluid from condenser to evaporator. The objective of this research is to improve capillary performance by making a straight pore called as lotus-type porous material (LTP) using centrifugal slip casting technique. Copper powder is used as wick materials due to its high thermal conductivity. A starch solution is used as binder material to make the copper slurry. Nylon wire is applied as straight pore mold. Freeze drying is applied to curing and demolding. Vacuum sintering is conducted to increase metallurgical bonding between the particle. The results show that centrifugal casting machine is capable to make a wick with LTP structure. On the performance department, capillary pumping is affected by rotation speed, powder size, and powder loading. The optimum parameters were copper powder with 260.54 μm powder size, 50% Powder Loading with 688 rpm rotation speed. The LTP wick is proved to have a higher capillary pumping capacity compared to the conventional wick. Further work is necessary to verify the performance of LTP wick in the heat pipe.

1. Introduction

Heat pipe is the most effective heat exchanger because of its ability to transfer large amounts of heat with the passive work system so that it does not require additional energy to operate it except the device itself [1]. The heat pipe is operated by utilizing latent heat and refrigerant to exchange large quantities of heat with small differences temperature across the area [2, 3]. The latent heat of the refrigerant is utilized to improve the thermal conductivity of the heat pipe. Example of heat pipe application is as a coolant to withstand the heat flux generated due to processor performance on CPU so that processor does not overheat.

Capillary wick is an important component of heat pipe that serves to re-drain condensed vapors to the evaporator quickly. The wick works based on the capillary behavior of the fluid [4]. This capability is one of the keys in determining of how the quality of pipe heat works. There are 3 types of capillary wick which are widely used: sintered powder, groove, and screen mesh. The sintered powder wick has better thermal performance than the screen mesh wick [5]. The sintered powder wick has a higher thermal resistance performance compared to the groove wick [6]. Sintered powder wick has a



very small structure that allows the flow of refrigerant works at high capillary pressure, however, it is prone to blockage so that the fluid flow is not able to penetrate the capillary wick [7].

In a 2014 article by Putra *et al.* introduced a capillary wick [8] based on biomaterials in the form of coral reefs. However, being a living creature, the coral reef will attract new problems if it is used for mass producing capillary wick, which eventually could lead into the destruction of underwater ecosystems. The conventional method to fabricate LTP metals utilizes pressurized hydrogen to control porosity and pore size [9]. One significant disadvantage is to rely on pressurized hydrogen gas, which requires the use of high-pressure chamber, so there is a definite need to develop fabrication methods that do not require high-pressure hydrogen [9]. LTP material using solid structure has been utilized with a loop heat pipes to improve the performance of battery thermal management systems so that it has high performance with long service life [10]. However the previous study used solid LTP for wick of the heat pipe. Therefore the objective of this research is to fabricate a hollow LTP for heat pipe using centrifugal slip casting and sintering process.

2. Experimental method

The fabrication of heat pipe by the method of centrifugal casting method that has the characteristics of Lotus-Type Porous is still relatively new. To get a heat pipe that has Lotus-type porous characteristics, the method is divided into three main stages: design centrifugal casting machine, centrifugal casting process, and densification.

The design of centrifugal casting machine using DC motor of 100-120V capacity with a maximum rotation speed reaching up to 888 rpm. Figure 1 shows the design centrifugal slip casting machine. Pulley and belt that serves to transfer the rotation from dc motor to pipe to produce centrifugal force on the pipe. Bearing is installed to restrain rotation axis. Support mold is designed to regulate the cavity structure on the capillary wick by being placed on both ends of the pipe. Figure 2 shows the illustration of support mold.

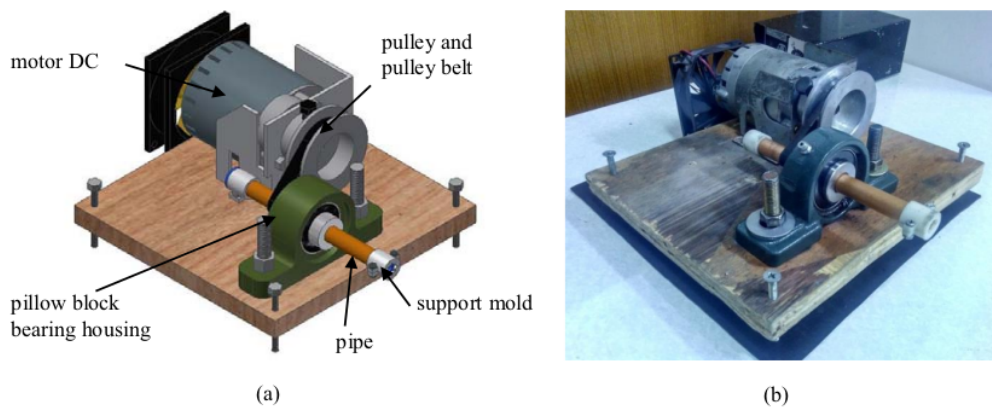

Figure 1. Centrifugal Slip Casting Machine: (a) centrifugal slip casting machine design with Inventor app, (b) centrifugal slip casting machine has been made.

Centrifugal casting process stage is the process of pouring copper powder that has been mixed with the binder material. The characteristic diameters of the used copper powder are 141.52 μm , 192.95 μm , and 260.54 μm respectively. The binder material used is tapioca. The ratio of mixture between copper powder and binder is 55% copper powder and 45% binder [11]. Lotus-type Porous Material (LTP) cavity builders use nylon-sized yarn of 0.12 micrometer. The principle of centrifugal casting is essentially done by pouring molten metal into a rotating mold. Due to the influence of the liquid metal centrifugal force

will be distributed to the wall of the print cavity and then freeze. This casting process takes approximately 30 minutes for each sample.

Densification stage or sintering process is to enter the green part that has been prepared into the vacuum furnace. Vacuum sintering is conducted to increase metallurgical bonding between the article. This process enters all green part samples into the vacuum furnace and then closes tightly and turns on the vacuum pump to make the atmospheric pressure decrease to -0.1 Mpa after which set up the temperature setting of 850°C [11]. Continuous vacuum is conducted during 60 minutes [11]. The aims to remove by product gases from sintering processes that potentially damage the microstructure of the product.

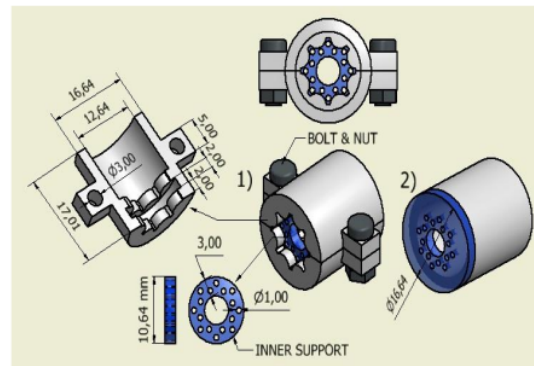

Figure 2. Design support mold.

In this research, capillary data were collected on 14 samples and 5 times for each sample. Data recording is done five times in one second using WinCT software and processed using Microsoft Excel and Origin Lab. Data retrieval on each seal with 3 main variables used as reference are Powder size (PS), Powder Loading (PL) and Pipe Rotation Speed (rpm) are shown in Table 1:

Table 1. Summarized data of 3 main sample variables.

Sample	PS (μm)	PL	RPM
S.1 ^a	141.52	40.00%	888
S.2 ^a	141.52	50.00%	888
S.3 ^a	141.52	55.00%	888
S.4 ^a	192.95	40.00%	888
S.5 ^a	192.95	50.00%	888
S.6 ^a	192.95	55.00%	888
S.7 ^a	260.54	40.00%	888
S.8 ^a	260.54	50.00%	888
S.9 ^a	260.54	55.00%	888
S.10 ^b	192.95	40.00%	888
S.11 ^b	192.95	50.00%	888
S.12 ^b	192.95	55.00%	888
S.13 ^a	141.52	50.00%	688
S.14 ^a	141.52	50.00%	788

^a with pore former

^b without pore former

Capillary pumping is the ability of a hollow material to create a capillary pressure difference [12]. The method used for testing capillary pumping performance is capillary pumping amount real time changing curve [4]. Figure 3 shows a schematic of capillary pump testing.

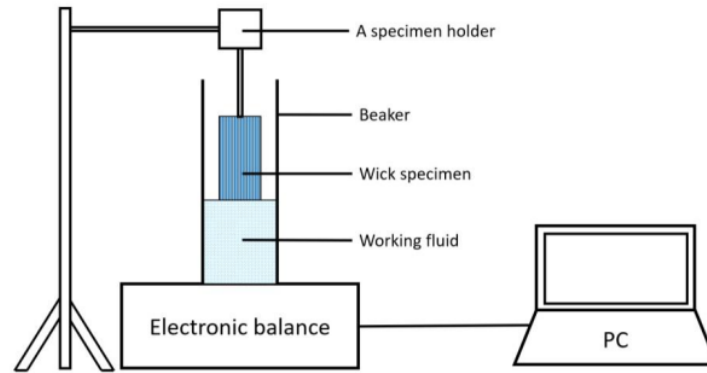

Figure 3. Schematic for measuring the capillary pumping amount changing curve.

Testing begins by filling beaker glass with working fluid which in this test is water. Then beaker glass is placed on an electronic scale that is connected to the computer to transfer data. Electronic scales used are A & D type GF-300. Then, once the computer and scales are ready, the porous wick sample is lowered slowly to the surface of the water. Data on the amount of fluid inhaled will be recorded in the computer which will be used to determine the capillary pumping rate [4].

Li *et al.* [4] states that the change in the capillary pumping amount curve can be described as shown in the equation (1),

$$y = y_0 + A x e^{-t/\tau} \quad (1)$$

where y_0 and A in equation (1) are related to the total amount of capillary pumping in hollow material. The time constants in the equation are related to the capillary pumping rate. The time constant can be used as a comparison of capillary pumping rate between hollow material. The higher the speed, it can be said the better the performance [4]. The derivative of equation (1) gives the capillary pumping rate as equation (2).

$$y'(t) = \frac{y_{sat}}{\tau} e^{-t/\tau} \quad (2)$$

In equation (2) the value (y_0/t) is the capillary pumping rate coefficient. In addition Li *et al.* [4] also concluded that along with increasing porosity, the performance of its capillary pumping will increase. When the porosity has the same value, then the material that has a narrower cavity will have better performance.

3. Result and discussion

Heat pipe wick was successfully fabricated using centrifugal slip casting process as shown in Figure 4. The thickness of wick is affected by viscosity. Figure 4 shows the difference in the diameter of the thickness of each sample wick. With the pouring volume of each pipe in the same way, then with an increasingly large powder loading (PL), the viscosity will also rise. Figure 4(d) shows the heat pipe without pore former for comparison with the sample Figure 4(a) Figure 4(e) shows the difference of wick diameter with the same PL and powder size but different rotational speed. Performance test results of capillary pumping of each sample heat pipe shown in Table 2.

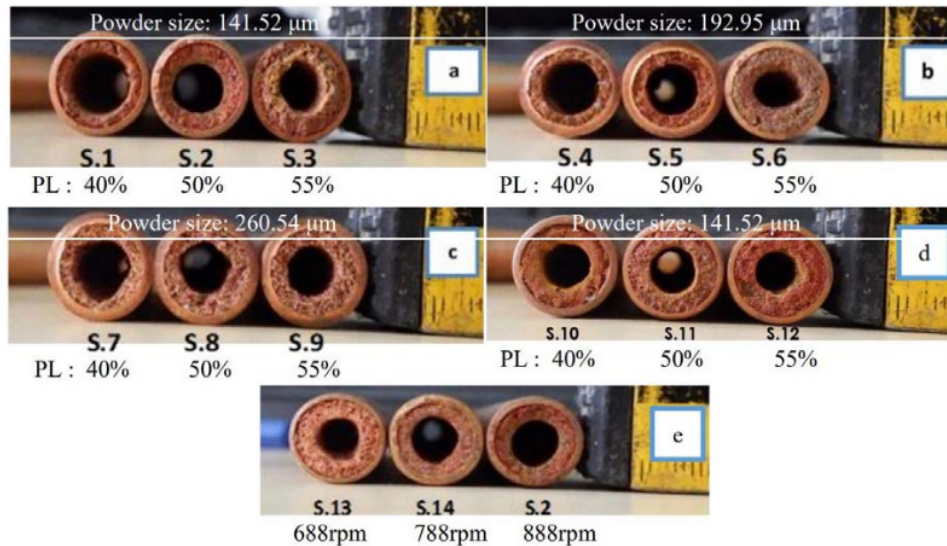

Figure 4. Sample heat pipe with centrifugal casting process: (a) wick with powder size 100 μm, (b) wick with powder size 150 μm, (c) wick with powder size 200 μm, (d) wick without pore former using powder size 150 μm, (e) comparison of rotation speed with powder size 100 μm.

Table 2. Summary of experiment result data.

Sampel	y0	Std. Error	t	Std. Error	y0/t	Std. Deviasi
S.1	0.974	0.00276	1.195	0.01891	0.850	0.20174
S.2	1.032	0.00284	1.107	0.01680	1.249	0.78677
S.3	1.356	0.00367	1.000	0.01679	1.519	0.65120
S.4	1.036	0.00275	0.808	0.01100	1.329	0.73733
S.5	1.107	0.00272	0.759	0.00672	1.514	0.64126
S.6	1.434	0.00377	0.767	0.01263	1.785	0.52146
S.7	1.277	0.00325	0.926	0.01539	1.486	0.48144
S.8	1.392	0.00346	0.806	0.01483	1.797	0.45628
S.9	1.508	0.00365	0.756	0.01590	2.189	0.64268
S.10	0.769	0.00136	1.001	0.01889	1.012	0.31260
S.11	0.830	0.00104	0.875	0.01561	1.211	0.44068
S.12	0.872	0.00201	0.860	0.01733	1.279	0.50358
S.13	1.254	0.00318	0.873	0.01633	1.604	0.65735
S.14	1.221	0.00263	0.951	0.01483	1.353	0.37634

There are three main variables that are used as references to study the relationship between Powder size (PS), Powder Loading (PL) and Pipe Rotation Speed (rpm).

Thickness of the capillary axis is influence by the amount of powder loading. Figure 5 shows that the Capillary Pumping Amount (CPA) capability increased when using larger powder sizes as well as the capillary wick with powder loading 55% with the largest capillary axis thickness. A result indicating that the powder size 260.54 μm and PL 55% remain the best. The larger powder size will produce a larger cavity so that the time required to reach the maximum amount of fluid that can be absorbed by the capillary axis becomes relatively shorter.

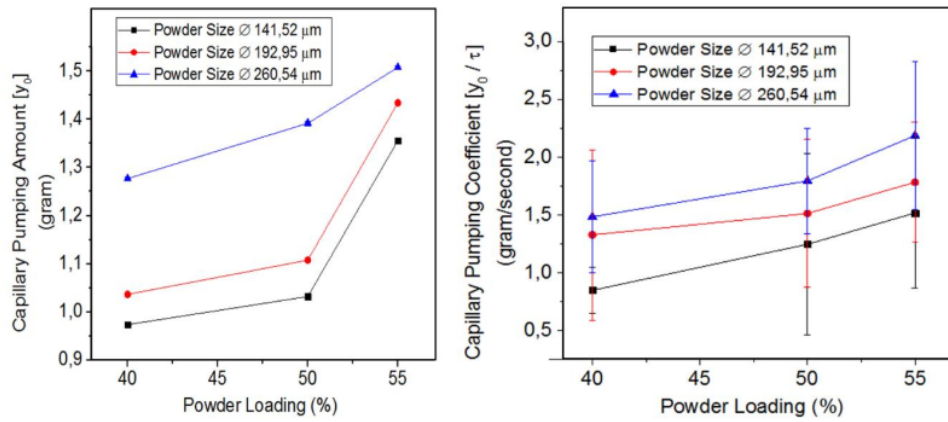

Figure 5. Capillary pumping as a function of powder loading for different powder size.

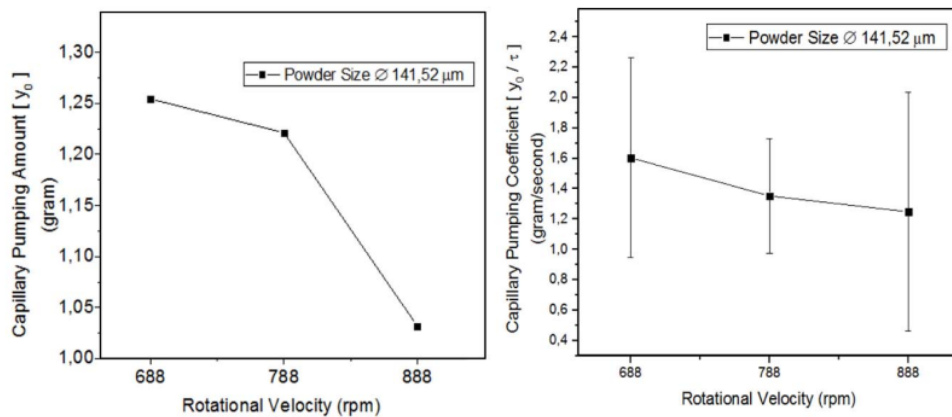

Figure 6. Graph comparison between rotational velocity and capillary pumping.

Variations of different rotation speeds will form capillary wick with different thickness because the force received by the slurry is different is shown in Figure 6. According to the effect of powder size as shown in Figure 5, the result of CPA which is influenced by rotation speed will have the similar trend with different powder size, so the optimum parameters are copper powder with powder size 260.54 μm, powder loading 55% and will be more optimum when done at 688 rpm rotation speed. However, the capillary wick fabricated with a 55% PL composition tends to be more difficult to produce capillary wick with hollow characteristics, because the slurry dries faster due to the higher viscosity of the slurry and makes it more difficult to be evenly distributed on the inside of the pipe during the centrifugal casting process. So the optimum parameter to produce an even more optimal capillary wick is when at 50% PL composition, using powder size 260.54 μm, and 688 rpm rotation speed.

The LTP wick performs higher capillary pumping capacity. The use of yarn as a pore former in the manufacture of Lotus-Type Porous Material on the capillary wick shows improvement in ability when compared with no pore former. Figure 7 shows the performance comparison of the sintered copper

powder capillary wick seen in terms of capillary pumping rate coefficient (CPR Coeff.) with the recommended optimum parameter reaching 1.198 gr/s, while the CPR Coeff. research that the authors do, the sample with the optimum parameters obtained is 1797 gr/s, a result that shows improvement in the performance from previous research.

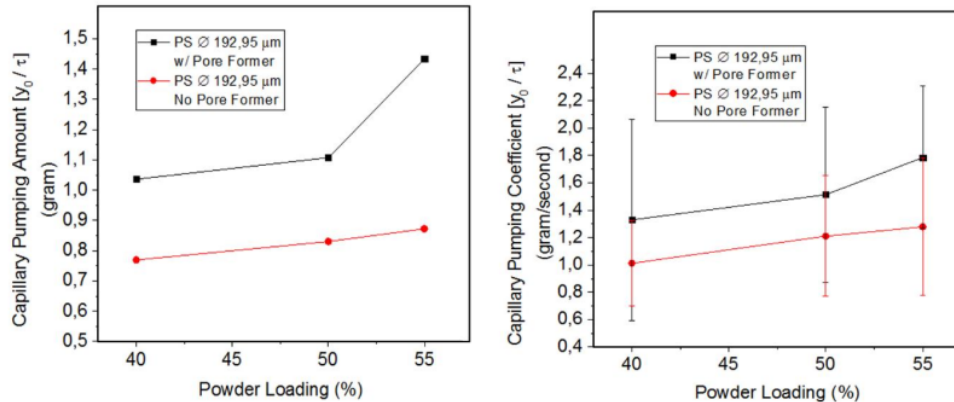

Figure 7. Graph comparison between with pore former and without pore former.

4. Conclusion

Copper LTP wick with hollow structure has successfully fabricated using centrifugal slip casting method followed by sintering process. The mold is used to maintain the structure of the pore former so as not to deform when the centrifugal casting process takes place. The sintering method by re-vacuum process can reduce the occurrence of decarburization or oxidation on the capillary wick. The optimum parameters of centrifugal slip casting machine made are copper powder with powder size 260.54 μ m, Powder Loading 50% and will be more optimum when done at 688 rpm rotation speed. Performance maximum capillary pumping rate of LTP ranges from 1.329 gr/s to 1.785 gr/s.

Acknowledgment

The authors would like to thank LPDP Department of Finance of Republic of Indonesia under RISPRO 2014.

References

- [1] Putra N *et al.* 2015 *Experimental Thermal and Fluid Science* **66** 13-27
- [2] Faghri A 1995 *Heat pipe science and technology* **1** Global Digital Press Washington DC
- [3] Faghri A 2012 *Journal of heat transfer* **134(12)** 123001
- [4] Li J Zou Y and Cheng L 2010 *Experimental Thermal and Fluid Science* **34** 1403-08
- [5] Kumaresan G *et al.* 2014 *International Communications in Heat and Mass Transfer* **57** 208-15
- [6] Russel M K *et al.* 2011 *Applied Thermal Engineering* **31(1)** 69-76
- [7] Korn F 2008 *Heat pipes and its applications* MVK160 Project Reports
- [8] Putra N *et al.* 2014 *International Journal of Thermal Sciences* **76** 128-36
- [9] Lee Y and Hyun 2012 *Material Letters* **78** 92-4
- [10] Ariantara B Putra N and Supriadi S 2018 *IOP Conf. Ser.: Earth & Env. Sci.* **105** 012045
- [11] Supriadi S *et al.* 2016 *Applied Mechanics and Materials* **819** 601-5
- [12] Dullien F A L and Brenner H 2012 *Porous Media: Fluid Transport and Pore Structure.*: Elsevier Science

Development of lotus-type porous material for heat pipe application using centrifugal slip casting process

ORIGINALITY REPORT

13%

SIMILARITY INDEX

8%

INTERNET SOURCES

9%

PUBLICATIONS

3%

STUDENT PAPERS

MATCH ALL SOURCES (ONLY SELECTED SOURCE PRINTED)

4%

★ hdl.handle.net

Internet Source

Exclude quotes On

Exclude matches < 1%

Exclude bibliography On