

Designing Pulper as Efforts to Increase Production Quality of Black mulberry (*Morus nigra*) Juice

by Yusman Taufik -

Submission date: 01-Nov-2021 07:04AM (UTC+0700)

Submission ID: 1689319277

File name: 02._20160810_Designing_Pulper.pdf (7M)

Word count: 3895

Character count: 24289



PROCEEDING

the 2nd International conference
on Sustainable **Global Agriculture
and Food**

Safeguarding
Global Consumers:
**Innovation in Food Science
and Technology**

www.icsaf2016.com



Semarang, Indonesia, 09 – 10 August
2016
ISBN 978-602-6865-43-4



PROCEEDING

the 2nd International conference
on Sustainable **Global Agriculture
and Food**

Safeguarding Global Consumers: Innovation in Food Science and Technology

Editor :

Dr. R. Probo Nugrohedhi, Msc.
Katharina Ardanareswari, STP., Msc.
Ivone E. Vernandez, SSi, Msc.

Reviewer :

Dr. V. Kristina Ananingsih, MSc.
Dr. Lindayani, MP.

TABLE OF CONTENTS

TABLE OF CONTENTS	ii
PREFACE	v
1 KEYNOTE SPEAKER	1
The 7 Challenges of Indonesian Rice Farmers	2
ORAL PRESENTATION	25
1 SENSORY AND FOOD PRODUCT DEVELOPMENT	26
Product Properness Analysis of Instant Uduk Rice (Study of Consumers Acceptance Reviewed by Fondness Level)	27
Development of Mungbean Tempeh Production as Alternative Tempeh	36
1 FOOD QUALITY AND SAFETY	51
The application of “Bioextract” or “Bio-fermented solution” for treatment of domestic wastewater	52
Effect of Carageenan from Local Seaweeds on Bread Quality	62
The evaluation of physicochemical characteristics of royal icing sugar made from three different white eggs	78
The Development of <i>Centella asiatica</i> Extract-Loaded BSA Nanoparticles Production to Improve Bioavailability	86
Assessment of Antimicrobial Activity of Concentrated Hypothiocyanite against <i>Escherichia coli</i> in Basic pH Environment	94
Supplementation of Prebiotic Iles-Iles as a Source of Carbon in the MRS Media For Growth of <i>Lactobacillus casei</i>	102
Lactic Acid Bacteria Isolated From Fermented Foods Made of Indonesian Local Sources: Potential and Application	108
The antibacterial and Antioxidant Activity of <i>Zingiber Officinale</i> Rhizomes (Ginger) in Thailand	122
1 FOOD PROCESSING AND ENGINEERING	129
The effect of dry cell <i>Haematococcus pluvialis</i> equivalent to Astaxanthin extracted for Color enhancing in goldfish	130
Designing Pulper as Efforts to Increase Production Quality of Black mulberry (<i>Morus graja</i>) Juice	138
Evaluation of Ginger (<i>Zingiber officinale</i> Roscoe) as Antioxidative Agent in Protein Reaction Characteristics of Sweet Bread	146
Examination of Antioxidant Activity and Color Characteristic of Herbal Infusion From Bursop Leaves	152
Potency of High Protein Oyek for Decreasing Cholesterol of Diabetic Rats	159
Phenolic contents and antioxidant activities of <i>Sonneratia caseolaris</i>	170
Alpha-Glucosidase Inhibitory Effect of Methanolic Extracts from Indonesian Plants	184
Spectrophotometric quantification of collagen in commercial beauty drinks	195
1 2 nd International Conference on Sustainable Global Agriculture and Food (ICSAF) “Safeguarding Global Consumers: Innovation in Food Science and Technology” Semarang, 9-10 th August 2016	ii

Impact of Citric Acid Immersion on the Physicochemical and Microbiological Characteristics of Curcuma Dried with Solar Tunnel Dryer	201
1 AGRICULTURE AND FOOD SECURITY	211
Bioprospecting of Brown Macroalgae From Java Island's Southern Coast, Gunung Kidul Coast of Yogyakarta and Binuangun Coast of Banten as Source of Lectins	212
1 NUTRITION AND CULINARY SCIENCE	226
Effect of Surfactant on Cellular Uptake of Human Serum Albumin Nanoparticles	227
Alpha-Glucosidase Inhibitory Effect of Methanolic Extracts from Indonesian Plants	240
Potency of high protein <i>oyek</i> for decreasing cholesterol of diabetic rats	249
1 POSTER PRESENTATION	258
Phenolic contents and antioxidant activities of <i>Sonneratia caseolaris</i>	259

PREFACE

1 On behalf of Faculty of Agricultural Technology, Soegijapranata Catholic University (SCU), I would like to express my gratitude and warmest welcome to all of the participants of the 2nd International Conference on Sustainable Global Agriculture and Food Security (ICSAF). It is a great honour and pleasure for Soegijapranata Catholic University to host this ICSAF. This conference is conducted biannually to share the research findings, experiences and knowledge in recent trends of food science and technology.

The 1st ICSAF has been successfully held in Bangkok on 16-18 July 2014. As all the advisory board agreed, the organizing committee of this biannual ICSAF is consist of 4 (four) Universities, i.e.: Assumption University Thailand, Fu Jen Catholic University Taiwan, Saigon Technology University Vietnam and Soegijapranata Catholic University Indonesia. These events are only made possible due to cooperation and generous supports of advisory board from those four universities. I would therefore like to express my sincere gratitude to advisory board for trusting Soegijapranata Catholic University to host this 2nd ICSAF.

1 The theme of this 2nd ICSAF is “Safeguarding Global Consumers: Innovation of Food Science and Technology”. This conference is intended to bring together the perspectives and knowledge in safeguarding global consumers. The existing various disciplinary approaches and different research areas are accommodated in this conference to confer a good viewpoint and furnish a critical thinking about recent innovation in food science and technology.

In this special occasion, I would like to thank Rector of Soegijapranata Catholic University, Prof. Budi Widianarko for generous support to this conference. Please also allow me to express my gratitude to all the keynote speakers, presenters and all participants. I would like to thank all participants from 7 countries, i.e.: Netherlands, USA, Malaysia, Thailand, Vietnam, Taiwan as well as Indonesia. I would like to thank all the sponsors which provide the things that we need so that this 2nd ICSAF can be held. Also, I would like to convey my sincere thank to all the Committe members, who have contributed their time and effort to make this conference possible.

Finally, I hope we all have a fruitful discussion, meet new colleagues and experiencing in exchanging ideas and sharpening them so that we will be benefited by this conference. Also, I wish all of our guests to have a pleasant and meaningful stay here in Semarang. Thank you very much.

Sincerely yours,

Dr. Victoria Kristina Ananingsih
Dean of Faculty of Agricultural Technology
Soegijapranata Catholic University

3
2nd International Conference on Sustainable Global Agriculture and Food
(ICSAF)
“Safeguarding Global Consumers: Innovation in Food Science and
2
Technology”
Semarang, 9-10th August 2016

KEYNOTE SPEAKER

2nd International Conference on Sustainable Global Agriculture and Food
(ICSAF)
“Safeguarding Global Consumers: Innovation in Food Science and
Technology”
Semarang, 9-10th August 2016

ORAL PRESENTATION

2nd International Conference on Sustainable Global Agriculture and Food
(ICSAF)
“Safeguarding Global Consumers: Innovation in Food Science and
Technology”
Semarang, 9-10th August 2016

25

SENSORY AND FOOD PRODUCT DEVELOPMENT

Designing Pulper as Efforts to Increase Production Quality of Black mulberry (*Morus nigra*) Juice

Yusman Taufik, Yudi Garnida, Yellianty

Program Studi Teknologi Pangan-Fakultas Teknik, Universitas Pasundan

Jl. Setiabudhi 193 Bandung, West Java, Indonesia 40153

Correspondence e-mail: yusman_taufik@yahoo.com

ABSTRACT

Market demand for the product Black Mulberry fruit is very high, especially in the form of processed juice. In the process of making juice needed a tool that is used to separate the juice with pulp, the pulper. In designing pulper should be optimized and adapted to the product to be processed, so that it can produce fruit juice effectively and efficiently. The purpose of this study was to design and build a pulper which can be used in juice processing Black Mulberry effectively and efficiently to improve the quality and quantity of products. The methods used in this study is testing and optimization factor rotation speed, frictional forces, and perforation of the filtering devices on pulper, as well as an assessment of the quality and quantity of Black Mulberry juice products. The results of this research prototype pulper created with the following specifications: Dimensions: 0.35 x 0.75 meters; Construction: SS304 and Steel Profile; Electric Power: 1.5 HP; Operating Systems: Continuous. The trial results showed that the juice produced in accordance with the organoleptic response expected, and had good raw material efficiency. In addition, the specifications and the model, the resulting pulp can be immediately separated and the time required producing the juice to be faster than the process of crushing / pressing usual. From this study we concluded that the pulper built were optimal in producing juice Black Mulberry with both quantity and quality, and has the potential to be applied as processing technology in small and medium enterprises.

Keywords: black mulberry, *Morus nigra*, pulper

INTRODUCTION

The **current** market demand for the product Black Mulberry fruit is very good, other than in the form of fresh fruit also in processed form (which is a very attractive market) such as syrup, juice, jam, juice, dodol, puree, and tea leaves for a replacement. The juice is defined as a liquid extorted by pressure or other mechanical means to the edible part of the fruit, the liquid can be cloudy or clear fluid depending on the type of fruit used (Hulme, 1971 in Padma 1981). Meanwhile, according to Indonesian Industrial Standard (1979), is defined as a liquid juice obtained by extorting fruit, filtered or not, and intended for direct drinking fresh drinks (Peter, 1983). In the process of making juice to separate the juice needed a tool pulper to separate the juice with pulp.

The factors that affect the process of spending juice by using the tool pulper among others:

- Rotation speed of the tool
- Friction happens
- Perforation of filtering devices

The function of this tool pulper, which is to improve the process of spending the juice in a relatively short time, so that the processed juice employers no longer feel the loss with their production. And besides, for an SME the development of this technology, it would be obviously very favorable for the production generated by small businesses is increasing, wages are relatively cheap and the quality is guaranteed. To motivate farmers to grow and develop black mulberries that can lift the economy and to improve the resilience of farmers to save, usefulness and economic value of the black mulberry fruit. Therefore, a need to manufacture pulper tool that will give effect to the quality of black mulberry juice is produced as functional beverages produced.

METHODS

Calculation of dimensions

Calculating the dimensions of the tool is an activity to determine the size of the tools and modeling tools based on the results of the calculation of the size of the tool.

Framework designed using brackets with dimensions in accordance with the capacity and size of the desired device is based on medium-scale industries.

Using peeler tank ST 304 material and designed to be able to accommodate a capacity of 5 kg black mulberry with the cylindrical shape of the container, ie the calculation:

$$V = \pi.r^2.t$$

Preparation of Basic Design

The initial step of the design process of this engine is started with the initial drawing engine design.

Determination Instrumentation

Components of the tools used in the design and manufacture of machinery is the key instrument on - off and speed control. Button instrument is adapted to a commercially available goods.

2

2nd International Conference on Sustainable Global Agriculture and Food (ICSAF)

“Safeguarding Global Consumers: Innovation in Food Science and Technology”

Semarang, 9-10th August 2016

Detail Design

After going through the steps above then the machine design process is then performed a more thorough along with the specification tool.

Revised Pictures

Reviewing the re-design machines that have been drawn to further simplify the process of designing the next machine.

Overall Design Process

After designing the components - the main component and then do the process of designing the overall machine by assembling the components - the main component into a machine planned.

Animation

Creating animation tools before the assembly as a whole.

Assembling Tools

After designing a whole, then performed the assembly by assembling the components - the main component into a machine planned.

Equipment Test

Once the engine is assembled, then tested the machine in order to determine whether the machine that made it feasible or not feasible for use with the parameter: tank capacity, speed and pressing results.

RESULT

Results of design tools can be seen in Figure 1 and 2. The design of the tool is based on several considerations can be acquired when doing literature review.

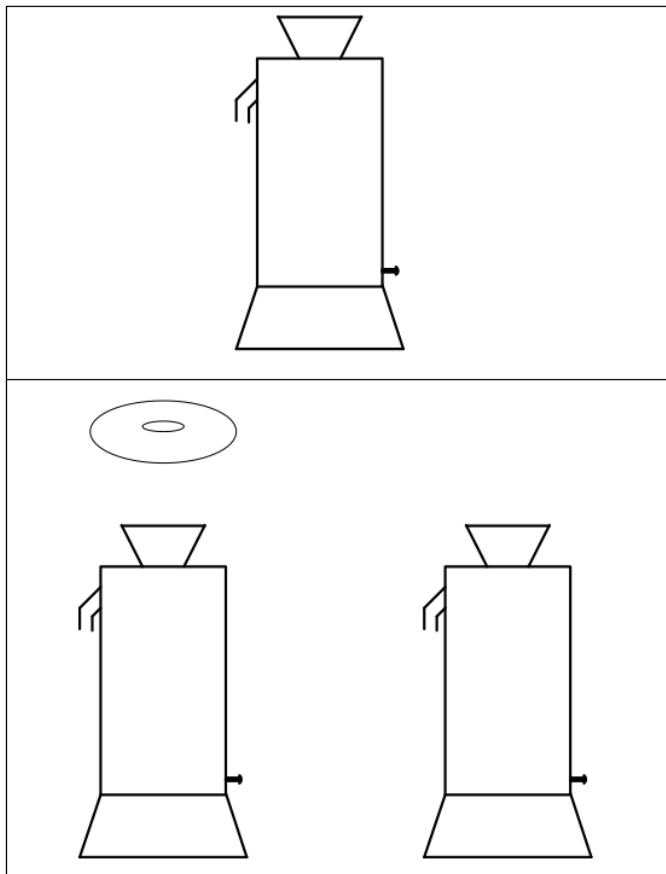

Figure 1. Design Results of Pulper

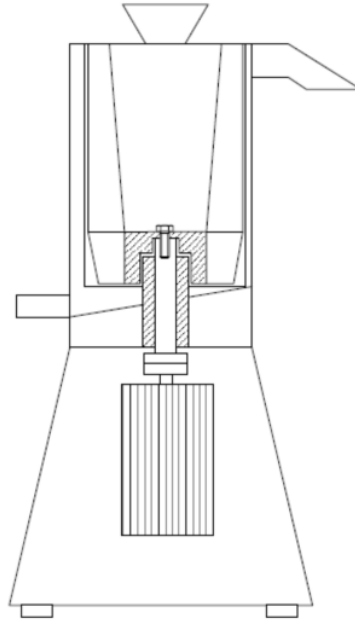

Figure 2. Inside of Pulper

Once the design is done, the next step is to manufacture pulper tool⁴ based on the design. The result of tool-making can be seen in Figure 3.



Figure 3. Results of design tools pulper

Table 1. Specifications of Pulper

Specifications	
Name	Fruits Pulper
Dimensions	350 x 750 mm
Construction	SS304 and steel profiles
Power	1.5 HP
Operation	Continue

Tool design results were then tested using the black mulberry fruit. Tests conducted in the laboratory instruments Machinery and Equipment Food Industry of Pasundan University. Results of testing tools can be seen in Figure 4.



Figure 4. Results of testing tools pulper

The test results indicate that the tool tool design results can be used to produce the black mulberry juice. Characteristics of the black mulberry juice obtained in the form of fruit juice does not have pulp but still have fruit pulp. Results juice produced as expected. The existence of fruit pulp obtained in processing results are expected to increase the fiber content of fruit so that it can improve the nutritional value may also reduce the need for food additives, such as stabilizers.

The next stages of research that will be done is to research the manufacture of beverages ready-made from Black Mulberry juice as a drink with health functions. Results were then expected to become the basis of making instant beverage products made from Black Mulberry Juice can be applied to both small-scale industries, medium, even large industry.

CONCLUSIONS

In **this** study it can be concluded that the results pulper design tool can be used to produce refined black mulberry juice in accordance with the expected character.

ACKNOWLEDGMENTS

Thanks to the BP3IPTEK

REFERENCES

- Anonim.2009. Robinia Pseudacacia. - Leguminosae Black Mulberry (*Morus nigra*)
- Anonim. 2009. Murbei, <http://www.herbal-obatalami.com>.
- AOAC. 1995. Official Methods of Analysis of International. 16th Edition, Association of Official Analytical Chemists, Inc., Washington, DC.
- Apriyantono, (1988), Petunjuk Laboratorium Analisis Pangan, Penerbit PAU Pangan dan Gizi IPB, Bogor.
- Astutik, S.,. 2009. Murbei, Tanaman Berhasiat dan Bermanfaat, sehat.wordpress.com.
- Baedhowie, M. and S. Pranggonawati, B.Sc., .1983. Petunjuk Praktek Pengawasan Mutu Hasil Pertanian I, Penerbit Departemen Pendidikan dan Kebudayaan, Direktorat Pendidikan Menengah Kejuruan.
- Buckle, A. K., R.A. Edwards., G. H. Fleet., and M. Wooton..1987. Ilmu Pangan, Penerbit Universitas Indonesia (UI-PRESS), Jakarta.
- Cruess, W. V., .1985. Commercial Fruit and Vegetable Product, Mcgraw-Hill Book Co., Inc. New York.
- DeMan, J., .1997. Kimia Makanan, Edisi Kedua, Penerbit ITB, Bandung.
- Endriany, R., .1998. Mempelajari Pengaruh Penambahan Pektin dan Gula Terhadap Mutu Jam dari Pulp Jeruk Siam, Skripsi, Universitas Pasundan, Bandung.
- Garsari .1999. Pengaruh Konsentrasi Sukrosa dan Konsentrasi CMC Terhadap Karakteristik Konsentrat Bubur Buah Jeruk Fremont, Skripsi, Universitas Pasundan, Bandung.
- Gaspersz, V., .1995. Teknik Analisis dalam Penelitian Percobaan, Cetakan Kedua, Penerbit Tarsito, bandung.
- Glicksman, M., .1969. Gum Technology in Food Industry, Academic Press, New York, San Francico, London.

Goel, R. K., 1980. Food Industrial manual Technology of Food Product (Food Processing Industries), Small Business Publication, Roop Negar, Delhi.

100 mg sample was immersed in 500 μ l ddH₂O for 30 min. In every 10 min intervals, the solution was vigorously shook with vortex for 1 min. After 30 min, the sample was centrifuged in 2000 rpm, for 5 min. The supernatant obtained was albumin. This procedure was repeated twice by immersing the solid residue in 400 μ l ddH₂O for 5 min followed by centrifugation. The obtained albumin was combined.

Globulin is the NaCl-soluble protein fraction. The solid residue left from albumin extraction was used for globulin extraction which followed the described method above, with NaCl 0.5 N as immersion solution. The supernatant obtained was globulin.

For gliadin extraction, the left solid residue should be rinsed first. It is immersed in 400 μ l ddH₂O and vigorously shook with vortex for 1 min, left aside for 5 min, and centrifuged in 2000 rpm for 5 min. The left solid residue was used for gliadin extraction with the method described above, with ethanol 70% for the solvent. After three times centrifugation which results in gliadin fraction, the left solid residue was immersed in 400 μ l mixed solution of 50% 1-propanol + 1% DTT for 30 min. In every 10 min intervals, the solution was vigorously shook with vortex for 1 min. After 30 min, the sample was centrifuged in 2000 rpm for 5 min. The obtained supernatant was glutenin.

Electrophoresis

The electrophoresis procedures was followed Bollag & Stuart (1991) with modification). For SDS-Page, 12.5% Separating Gel and 4% Stacking Gel was used. Glutenin extract was added with 2x Sample Buffer with 1:1 ratio and heated in waterbath for 5 min in 90° C. An amount of 1 μ l coloring agent (1g Bromophenol Blue + 10 ml ddH₂O) was added. This colourized sample (20 μ l) was added to the well. SDS-PAGE was operated in 300V, 50A for 135 min. After the gel was taken, the gel was colorized with Coomassie Blue. The gel was agitated in Coomassie Gel Stain for 45 min, rinsed with ddH₂O, and agitated in Coomassie Gel Destain overnight. The gel was scanned afterwards and the molecular weight of the fractionated protein was calculated according to low molecular weight BSA.

RESULTS AND DISCUSSION

Ginger-supplemented dough Hardness

During dough mixing, the air is incorporated during mixing and contributes in increasing oxygen contact to the sulfhydryl residue. The presence of oxygen triggers oxidation reaction of disulfhydryl residue and results in the formation of interchain disulphide bond. The formation of disulphide bonds results in higher elasticity yet lower hardness. However, the addition of antioxidant compound reverse this process. Antioxidant inhibits the oxidation reaction and reduces disulphide bond produced to its initial form (Ananingsih & Zhou, 2011). This chemical reaction also affects physical characteristic of the dough.

In this research, antioxidant was added in the form of ginger powder. Addition of 1.5 and 3% ginger in the dough affected the hardness of the dough significantly. Dough with higher ginger concentration showed higher hardness (Table 1).

3

2nd International Conference on Sustainable Global Agriculture and Food (ICSAF)

“Safeguarding Global Consumers: Innovation in Food Science and Technology”

Semarang, 9-10th August 2016

Table 1. Hardness of ginger-supplemented dough

Ginger Concentration (%)	Hardness (gf)
0	28,63 ± 1,74 ¹
1.5	41,68 ± 1,22 ²
3	48,91 ± 1,37 ³

^a Each value represents the means ± standard deviation of three replicates.

^b Different superscript in the same column shows significant difference (p<0.05) according to Duncan's Multiple Range Test

Molecular protein fraction analysis

SDS-PAGE analysis is intended to separate protein into fractions based on its molecular weight (Wasinger *et al.*, 1995). Flour contains two protein type, gluten and non-gluten. Albumin and globulin are classified as non-gluten protein, while gliadin and glutenin are classified as gluten protein. Physical characteristic of dough is highly affected by the gluten protein. In this research, glutenin showed higher portion than gliadin (Fig. 1). Glutenin is the major protein fraction of flour which consists about 45% of flour total protein (Zilic *et al.*, 2011). Glutenin is composed of polypeptide chain connecting by interchain disulphide bond (Zilic *et al.*, 2011), therefore it plays a major role in determining dough elasticity. Based on that reason, electrophoresis analysis was conducted for the glutenin fraction only. Glutenin fraction of each sample consists of different amount of protein sub unit chain.

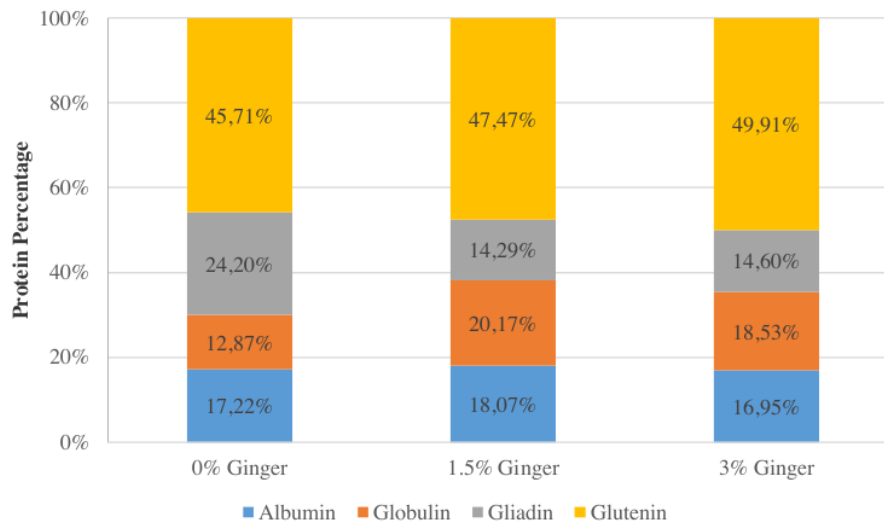

Fig. 1. Protein fraction percentage of ginger-supplemented dough

Addition of antioxidant compound may dissociate the disulphide bond and increase the amount of free sulfhydryl group (Ananingsih & Zhou, 2011). Ginger addition in various concentration resulted in different amount of protein subunit in each concentration. The control sample showed 7 protein subunit, i.e. 63.73 kDa; 57.20 kDa; 52.82 kDa; 46.08 kDa; 42.68 kDa; 39.86 kDa and 31.30 kDa. Meanwhile, sample with 1.5% ginger powder contained 5 protein subunit i.e. 63.01 kDa; 55.13 kDa; 52.52 kDa; 46.88 kDa; and 41.01 kDa. Sample with 3% ginger powder contained 5 subunit, i.e. 61.94 kDa; 56.55 kDa; 51.20 kDa; 43.41 kDa and 41.72 kDa (Fig. 5). Oxidation and free radical formation during mixing may cause a breakdown of disulphide bond to form sulfhydryl group, therefore it may change the molecular weight of gluten protein.

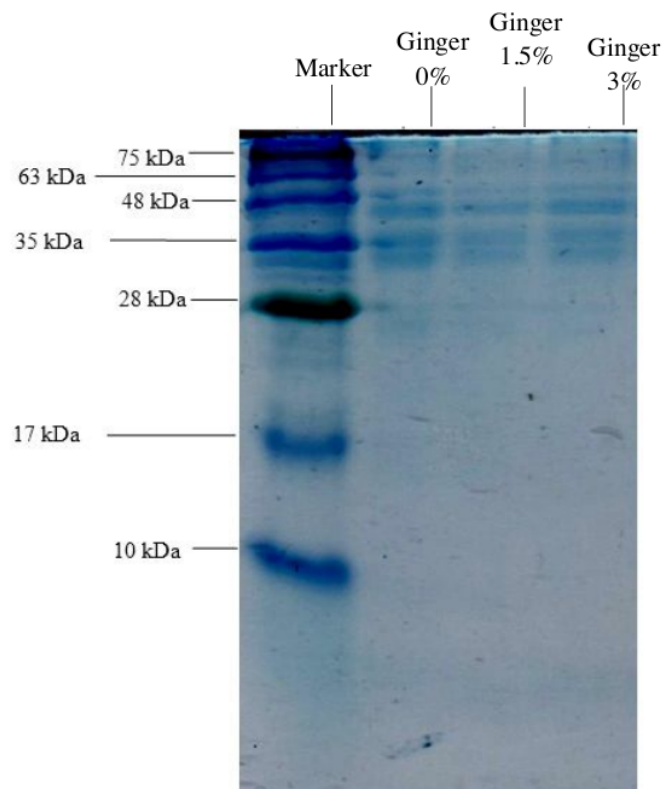

Fig. 2. Glutenin protein fraction profile of ginger-supplemented dough

Conclusion

Addition of ginger powder increased dough hardness. Higher ginger powder concentration resulted in higher dough hardness. Glutenin is the major protein of ginger-supplemented dough. Addition of ginger powder triggered change of molecular weight of glutenin protein fraction. Different amount of protein subunit with different molecular weight in each fraction was found.

References

- Ananingsih, V. K., and Zhou, W. (2011). Effect of Green Tea Extract on Large Deformation Rheological Properties of Steamed Bread Dough and Some Quality Attributes of Steamed Bread. In *11th International Congress on Engineering and Food*, (pp. 647 – 648). Athens, Greece.
- Balachandran, S., S. E. Kentish and R. Mawson. (2006). The Effect of Both Preparation Method and Season on the Supercritical Extraction of Ginger. *Sep. Purif. Technol.* 48 (2) : 94-105.
- Bollag, D.M., and Stuart, J.E. (1991). *Protein Methods*. Department of Biochemistry. University of Geneva. Geneva. Switzerland.
- Hoseney, R. C. (1994). *Principles of Cereal Science and Technology* 2nd Edition. American Association of Cereal Chemist, Inc. USA.
- Lookhart, G. and S. Bean. (1995). Separation and Characterization of Wheat Protein Fractions by High-Performance Capillary Electrophoresis. American Association of Cereal Chemist, Inc. USA.
- Vankar, P. S., Shanker, R., Srivastava, J., and Tiwari, V. (2006). Change in Antioxidant Activity of Spices Turmeric and Ginger on Heat Treatment. Di dalam Purnomo, H.,
- Jaya, F., and Widjanarko, S. B. (2010). The Effects of Type and Time of Thermal Processing on Ginger (*Zingiber officinale* Roscoe) Rhizome Antioxidant Compounds and its Quality. *International Food Research Journal*. 17: 335-347.
- Wasinger, V. C., Cordwell, S. J., Cerpa-Poljak, A., Yan, J. X., Gooley, A. A., Wilkins, M. R., Duncan, M. W., Harris, R., Williams, K. L. and Humphery-Smith, I. (1995). Progress with Gene-product Mapping of the Mollicutes: *Mycoplasma Genitalium*. *Electrophoresis*. 16:1090-4.
- Zilic, S., Miroljub B., Mirjana P., Dejan D., and Dragana I. M. (2011). Characterization of Proteins from Grain of Different Bread and Durum Wheat Genotypes. *International Journal of Molecular Sciences* 12, 5878-5894.

Designing Pulper as Efforts to Increase Production Quality of Black mulberry (*Morus nigra*) Juice

ORIGINALITY REPORT

21 %
SIMILARITY INDEX

21 %
INTERNET SOURCES

6 %
PUBLICATIONS

3 %
STUDENT PAPERS

PRIMARY SOURCES

1 proceedings.unika.ac.id 15%
Internet Source

2 repository.unika.ac.id 3%
Internet Source

3 www.scilit.net 2%
Internet Source

4 fapet.ub.ac.id 1%
Internet Source

5 Submitted to Coventry University 1%
Student Paper

6 Submitted to South Bank University 1%
Student Paper

Exclude quotes On

Exclude bibliography On

Exclude matches < 1%